

CAD FILE:

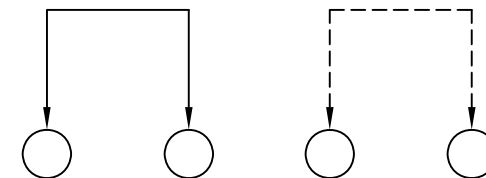

SCHEMATIC(NON-SHORTING)

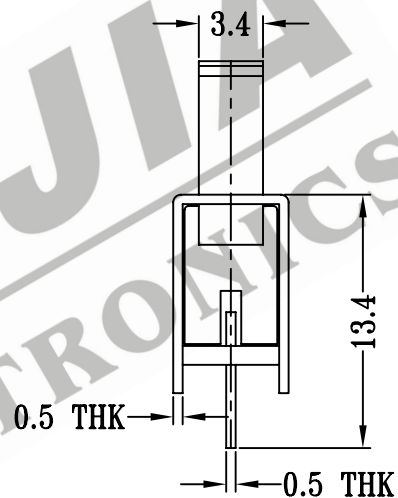
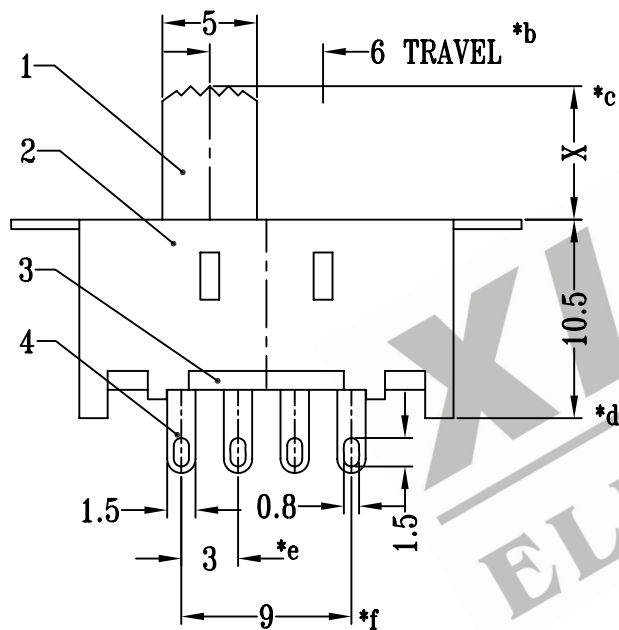
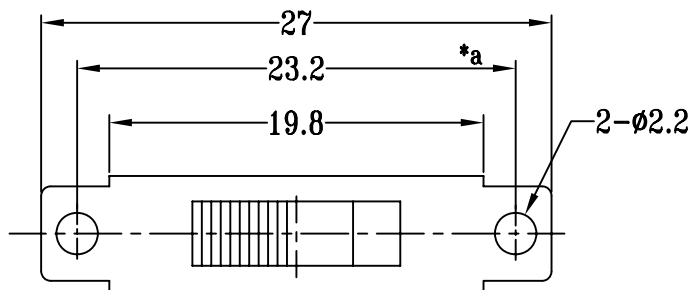
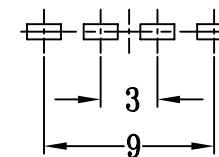

P.C.B LAYOUT

注：“*”表示关键尺寸（6个）

NO.	PARTS	MATERIALS	Q'TY	FINISH	TOLERANCE UNLESS SPECIFIED	SHENZHEN XIEJIA ELECTRONICS CO.,LTD.					
8						ISSUE		DATE		DESCRIPTIONS	APPD.
7	CONTACT(CLIP)	PBS STRIP	1	Ag PLATED	WITHIN: 1.5±0.1mm	TITLE : VERTICAL SLIDE SWITCH		UNIT : MM	DRWG NO.: XJ-DR-SS12L07-00		
6	STEEL BALL	STEEL	1	NATURAL	OVER : 1.5±0.2mm	MODEL: SS-12L07		SCALE: 5:2	DWN.	ZHOUYU	2004-11-5
5	SPRING	STEEL WIRE	1	TEMPER		ALL MATERIALS MUST BE COMPLIANT TO ROHS			CHK'D	FANGYING	2004-11-5
4	TERMINAL	BRASS STRIP	4	Ag PLATED OVER Ni PLATED					APPD.	KANGXINAN	2004-11-5
3	TERMINAL BASE	PHENOLIC RESIN	1	BLACK							
2	FRAME	STEEL STRIP	1	BLACK							
1	KNOB	POM	1	BLACK							